

Chilled Beams

Chilled Beams

TROX offers a vast variety of chilled beams. There are two kinds of beam types, active and passive. Both systems can be mounted either flush or exposed. In addition, TROX TCB series of beams are recessed into a ceiling void above a perforated ceiling tile.

Passive chilled beams are a simple yet effective cooling device comprising of a cooling coil within a casing. As warm air at ceiling level passes over the coil, which is cooled with chilled water (14°C), the warm air is cooled as it passes over the coil. The sides of the casing promote a stack effect within the beam. This directs cooled air down into the occupied zone. This air is then replaced by warm air from above the coil in a continuous motion.

Beam Type	Recessed	Flush	Exposed
Passive	✓	✓	✓
Active	—	✓	✓

Active chilled beams use primary air to create a low pressure inside the casing which draws or induces room air through a heated or cooled coil. The mixed primary and induced air is then discharged via slots into the occupied zone.

Typical selection parameters for TROX TCB Passive Chilled Beams

- Outputs from 125W/m to 350W/m with 1 row coils & 125W/m to 600W/m with 2 row coils
- Outputs of 300W/m give air velocity of 0.25m/s @ 1m below chilled beam
- Suitable for open ceiling areas & behind perforated ceiling tiles down to 30% free area
- Minimum 3.2mm post painted hole size
- Minimum 300mm ceiling void required

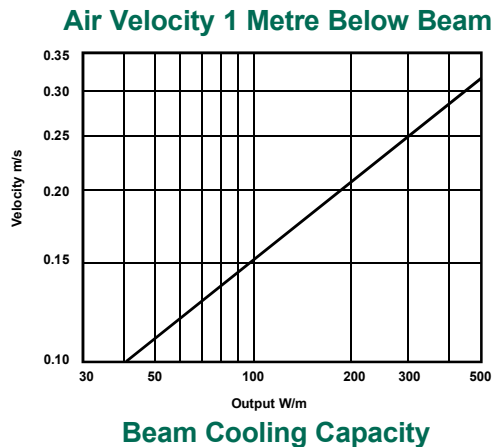

Typical selection parameters for TROX active chilled beams – DID300 / DID600

- Cooling output up to 500W/m
- Heating output normally 50% of cooling
- Typical installation from 1.8 to 3.6m ctrs
- Typical unit height 300mm
- Single beam lengths up to 3.6m
- Side, end & top entry air connections available
- Constant air volume preferred
- 1 or 2 way discharge

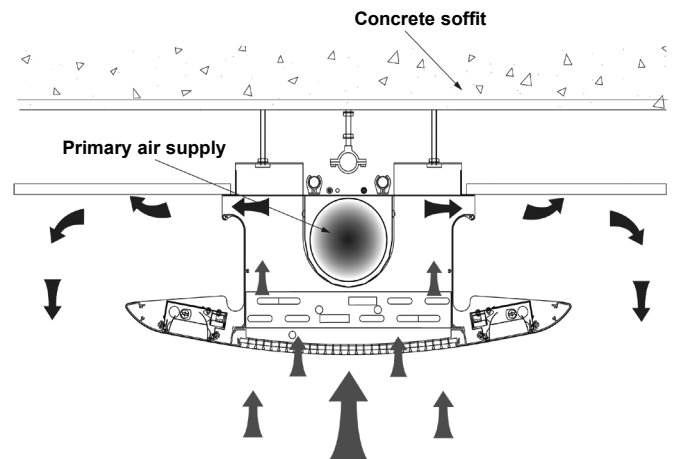

Multi-Service Chilled Beams combine cooling and/or heating with a range of other services including:

- | | |
|--------------------------|-----------------------|
| • Sprinkler Systems | • BMS cables |
| • Lighting | • Voice & data cables |
| • Public address systems | • CCTV |
| • Smoke detectors | • Smoke sensors |
| • PIR sensors | |

Recent advances in energy efficiency of MSCBs include the latest generation TROX high induction top discharge chilled beam. Unlike conventional chilled beam designs, TROX top discharge delivers the highest outputs in sensible cooling for the same amount of fresh air supplied to the beam. This means the fresh air requirement to run the beam at a certain cooling capacity is minimised, allowing the AHU plant size to be reduced if necessary. The pressure loss for the air path going through the engine of the chilled beam is minimised, resulting in an increased induction ratio of recirculating room air.

