

PILLER UK Ltd

Introduction

Piller Power Systems GmbH has been manufacturing Rotary machine technology since 1909 and is Head-quartered in Osterode, Germany. Piller Power Systems is a subsidiary of Langley Holdings plc (Langley) domiciled in Retford UK. The organisation is unique in that it manufactures the complete range of power protection systems, comprising of three UPS technologies in the form of Hybrid Rotary UPS, Diesel Rotary UPS and Static UPS systems. Piller Power Systems is also a manufacturer of other power Improvement and Management Systems which include Voltage Stabilisers, Frequency Converters and Static Transfer Switches. The reputation of Piller machines is supported by a vast installed base. Piller UK has been selling and supplying UPS systems in the UK for over 30 years.

UNIBLOCK UBR Hybrid Rotary UPS

The UNIBLOCK UPS system combines the latest digital control techniques and power electronics with the superior load-handling characteristics of Rotary machines. The most notable difference with this system is the internally redundant paths (effectively 2 UPS in 1) in addition to the usual bypass path associated with static designs. In normal operation, the supply is via a static switch, directly to the motor-generator set. This provides an enhanced efficiency path. The system also has a rectifier/inverter path as the active redundancy and the automatic bypass as the emergency redundancy. The UNIBLOCK UBR Hybrid Rotary UPS is ideal for IT data loads where the ability to handle the load combined with maximum availability is paramount.

Key Features

- Reliability greater than 600,000 hours MTBF
- Very high on-line efficiency - low operational costs
- Virtually unity input power factor
- Sinusoidal input current - no filters required!
- Superior load handling - full kW output from 0.8 lagging to 0.8 leading power factor
- Natural sine wave output
- Inherent fault clearing (including battery operation)
- External source synchronisation capability as standard
- No harmful battery ripple enhancing battery life
- Options for battery & battery-less energy storage
- No power capacitors
- Dual fully independent inputs
- 100% unbalanced load
- Redundant controls

Direct-cooled Option

UNIBLOCK UBR Watercooled

- No A/C requirements as UPS has 'built-in' heat exchanger
- Reduced space
- Improved system efficiency
- Reduced running costs
- Silent - 65dBA@1m
- Closed air circuit for dirty environments

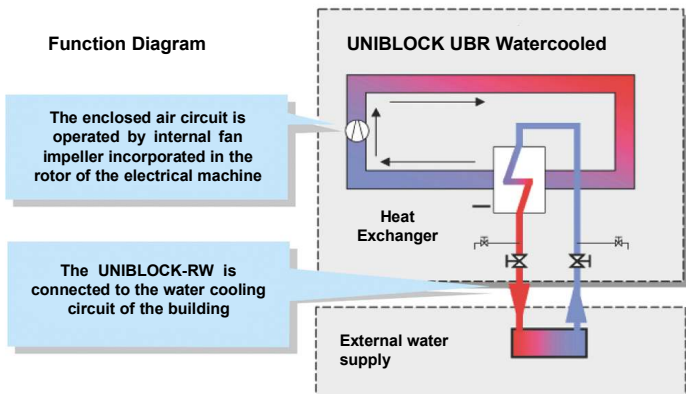

Piller UK Ltd
Westgate Building
Phoenix Way
Cirencester
Glos GL7 1RY

Tel : 01285 657721
Fax : 01285 654823
Email : sales@piller.co.uk
Website : www.piller.com

