

82 - Dynamic Diesel UPS

The NBDK DRUPS System in general is equipped with a Diesel engine (1), electromagnetic clutch (2), Synchronous alternator (3), Kinetic Energy module KIN (4), Choke (6), and the HITZINGER POWERCON Controller.

During stand-by operation critical load and the synchronous machine are both supplied via the choke from the mains, with the output frequency equal to the mains supply. The Synchronous machine maintains the consumer voltage constant, irrespective of the mains voltage fluctuations and supplies most of the load reactive power with the benefit of correcting the mains supply power factor to approximately unity.

The Choke / Synchronous machine combination also serves to largely isolate the critical load harmonic currents from the utility side and filter out any mains borne interference from the critical load.

Mains Supply

Consumer Voltage

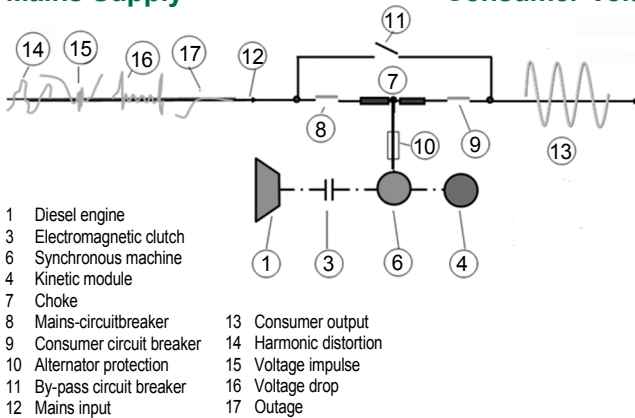

In stand by operation the circuit breakers (8) and (9) are closed, the By-Pass circuit- breaker (11) is open, the load is supplied with clean power through the choke from the mains and the synchronous machine (3) acts as a motor and supplies the critical load with the necessary reactive power. The equipment is running on synchronous speed (1500 rpm) the outer rotor of the Kinetic Module (4) storing the kinetic energy is rotating with 2600 rpm.

The Kinetic Energy Module is completely brushless and site maintainable being designed for maximum availability. The KIN consists of two rotating parts, the inner and outer rotor.

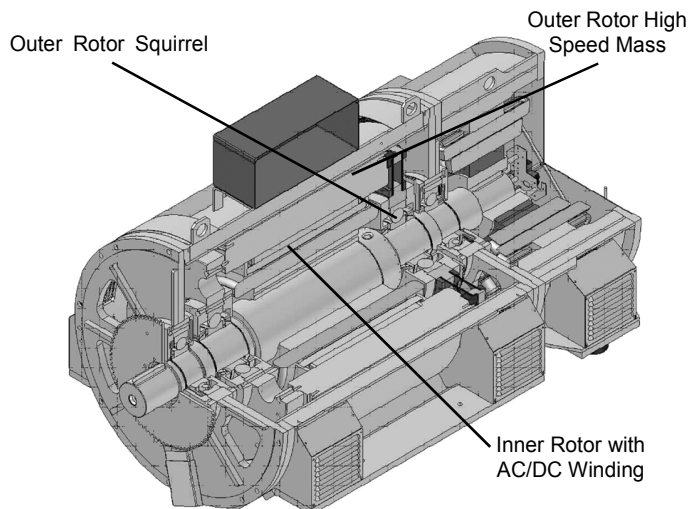

The outer rotor that is equipped with a squirrel cage rotates with 2600rpm and runs freely on the shaft of the inner rotor.

The inner rotor equipped with a specially designed winding rotating at synchronous speed (1500rpm) coupled via a flexible coupling to the synchronous alternator. In the event of a mains failure the magnetic field of the inner rotor brakes the outer rotor and keeps the speed of the synchronous alternator constant via a control unit.

The input stabilising filter system includes the coupling choke; this connects the input grid supply with the UPS high quality output supply. It allows large voltage differences between both AC systems by means of reactive currents for any direction, independent of the active power flow. The special design of the choke provides a high degree of decoupling in both directions between the input and output.

The output voltage and input current are completely independent of each other. It is possible with the coupling choke to prevent all the harmonics and transient events between input and output. Harmonics in the output current are not transmitted to the input side.

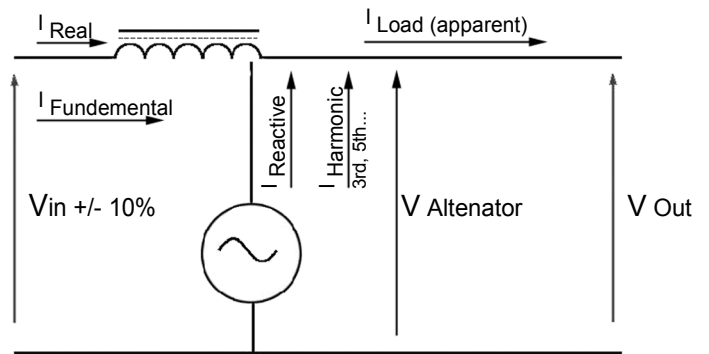

The input current consists only of the sinusoidal fundamental waveform required for power transfer. Likewise, Harmonics and transients in the input voltage have no effect on the quality of the output voltage. This independence is achieved through the calculated combination of the coupling choke high impedance characteristics to harmonic currents and the special design synchronous machine windings and selective damper cage representing a short circuit to these harmonics preventing reflection to the mains supply.

Hence the coupling choke provides;

- Static & Transient voltage decoupling of the input mains & the UPS Bus
- Harmonic Filtering
- Input load levelling irrespective of 100% unbalanced output load
- Input power factor correction >0.98 from 0-100% load at nominal voltage

In the event of input short circuit the current flow towards the grid network is limited by the choke at <200% $I_{nominal}$ until the input is disconnected. During this transient situation the coupling choke maintains the UPS bus voltage and ensuring all kinetic stored energy can be fully utilised for supporting the critical load.